



UNIVERSITY COLLEGE TATI (UC TATI)

FINAL EXAMINATION QUESTION BOOKLET

COURSE CODE	: DMT 1073
COURSE	: AUTOMATION TECHNOLOGY
SEMESTER/SESSION	: 2 - 2024/2025
DURATION	: 3 HOURS

Instructions:

1. This booklet contains **4** questions. Answer **ALL** questions.
2. All answers should be written in answer booklet.
3. Write legibly and draw sketches wherever required.
4. If in doubt, raise your hands and ask the invigilator.

DO NOT OPEN THIS BOOKLET UNTIL YOU ARE TOLD TO DO SO

THIS BOOKLET CONTAINS 7 PRINTED PAGES INCLUDING COVER PAGE

QUESTION 1

- a) State the definition of automation. (3 marks)
- b) Automation arises through three (3) levels. Describe these levels. (6 marks)
- c) Pneumatic systems are widely used in industry. Explain three advantages of pneumatic. (6 marks)
- d) Figure 1 shows a circuit used to control lamp 1 and lamp 2. In sequence, describing what happens during each of the conditions below:
 - i. When push button 1 (PB1) is pressed. (2 marks)
 - ii. When push button 1 (PB1) is released. (2 marks)
 - iii. When push button 2 (PB2) is pressed. (2 marks)
 - iv. When push button 2 (PB2) is released. (2 marks)
 - v. When push button 3 (PB3) is pressed once and released. (2 marks)

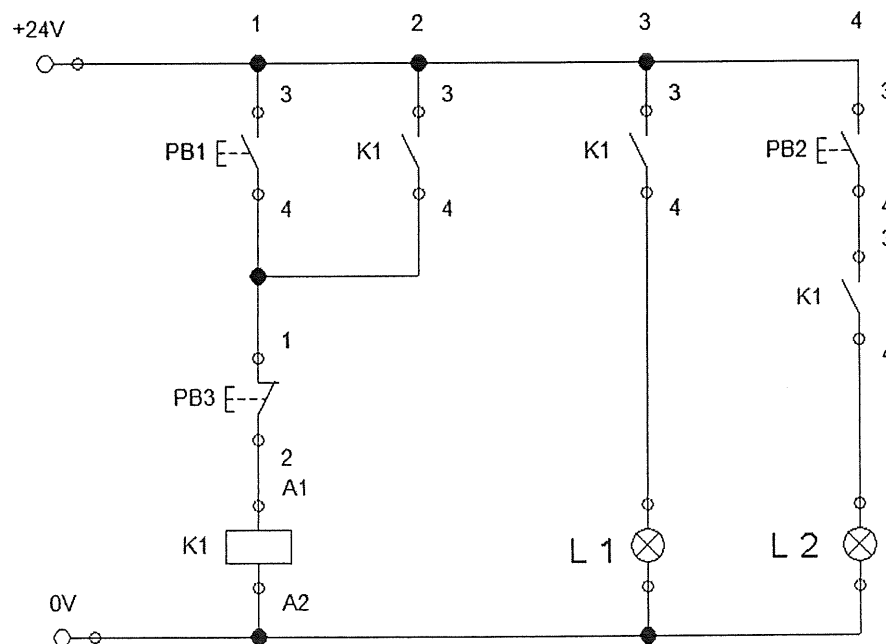

Figure 1

QUESTION 2

- a) State the meaning of sensor. (2 marks)
- b) Sensors can be classified into passive sensors and active sensors. Give four (4) examples of passive sensor. (4 marks)
- c) A system use to detect the metal inside food packaging. If the package contains metal in it, the piston will reject the package. By using suitable sensor:
- i. Draw pneumatic circuit for the system by using 3/2-way single solenoid with spring return valve. (4 marks)
 - ii. Produce electrical circuit connection for the following conditions. (4 marks)
- d) Draw symbol for 5/2-way pushbutton with spring return valve. (3 marks)
- e) By using the Programmable Logic Controller (PLC) system, a lamp will turn on when PB1 is pressed. The lamp will turn off when PB2 is pressed. (use SET/RSET)
- i. Draw PLC input/output wiring. (3 marks)
 - ii. Produce ladder diagram rung for the system. (5 marks)

QUESTION 3

a) Compare these three proximity sensors by completing Table 1. (6 marks)

Table 1

Types of proximity sensors	Symbol	Types of object detection
Capacitive sensor		
Inductive sensor		
Reed sensor		

b) Figure 2 shows the symbol of a relay. Describe the operation of this relay.

(5 marks)

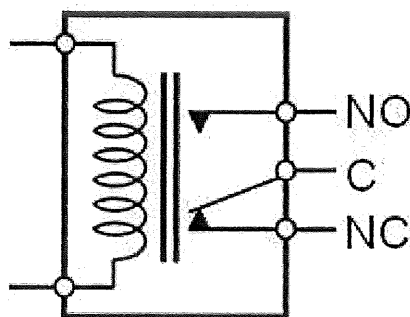

Figure 2

- c) By using single acting cylinder and 3/2-way single solenoid with spring return valve.
- Cylinder will extend when PB 1 and PB 2 are pressed at the same time.
 - Cylinder will retract when PB3 is pressed.
- i. Draw pneumatic wiring diagram. (5 marks)
- ii. Produce electrical circuit connection for the following conditions (9 marks)

QUESTION 4

- a) State the other four (4) types of PLC programming languages that are available to be used in the automation system. (4 marks)
- b) Give three (3) advantages of PLC. (3 marks)
- c) Every PLC needs a module to be plug into a common bus or rack to operate. Describe four (4) types of module and the function for each module. (8 marks)

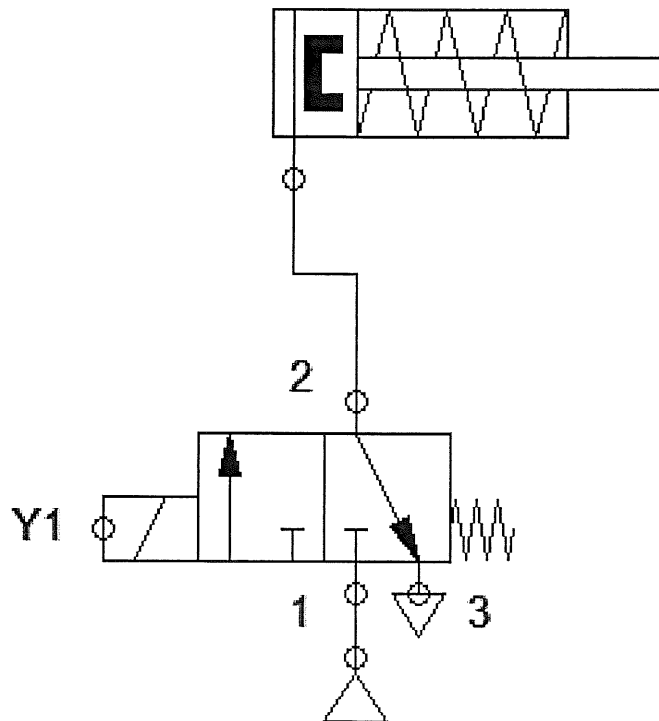

Figure 3

d) Based on Figure 3, a PLC system is used to activate cylinder based on the following condition:

- The cylinder is extending when pushbutton PB1 and pushbutton PB2 are pressed
- The cylinder is retracting by pressing pushbutton PB3.

i) **Produce** the ladder diagram program using **latching** instruction.

(5 marks)

ii) **Produce** the ladder diagram program using **SET and RSET** instruction.

(5 marks)

-----End of question-----

